

UL US LISTED
 File #E65324
 NEMA 4, 4X

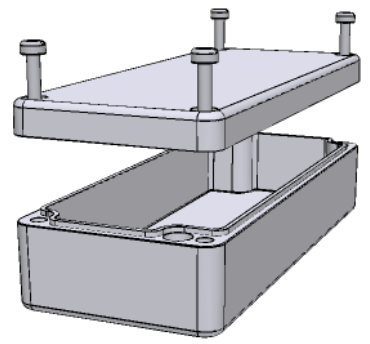

Ø4.50 mm THRU
 Ø8.30 mm ∇ 20.00 mm
 2X
 (MOUNTING HOLES)

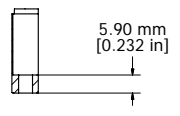
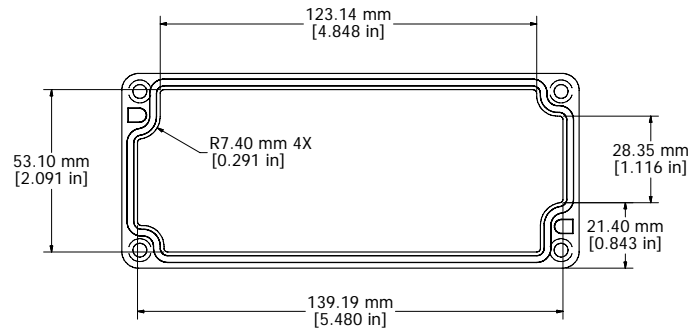
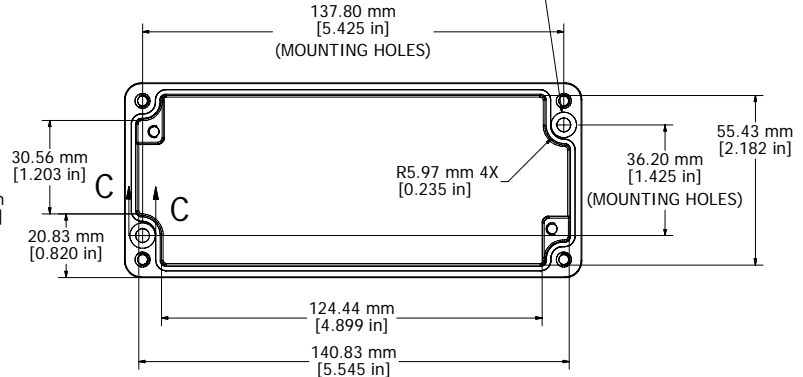
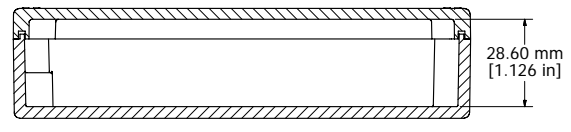

Enclosures can be Factory Modified (Milling, Drilling, Printing etc.)
 Contact Factory mjm@hammondmfg.com for quotes
 Solid models of this enclosure available in STEP or IGES.

NOTES	
Purchased assembly includes enclosure, M4x20 lid screws and M4x6 ground screws.	
Gasket - Preformed Silicone Rubber	
Cover screws should be torqued to 5-7.5 lbf.in (50-75 cN.m)	

1590Z063	
PART NUMBERS	
Basic Enclosure	1590Z063
Black Enclosure	1590Z063BK
Grey Enclosure - RAL7001 Gloss	1590Z063GY

HAMMOND MANUFACTURING™

1590Z063

www.hammondmfg.com